

INSTALLATION INSTRUCTIONS

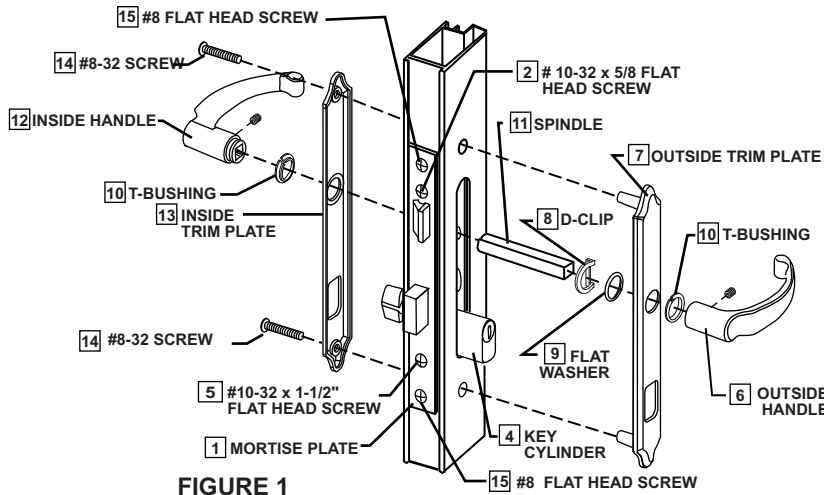

FIGURE 1

PARTS TABLE *

1. MORTISE PLATE
2. #10-32 X 5/8" FLAT HEAD SCREW
3. LATCH ASSEMBLY
4. KEY CYLINDER
5. #10-32 x 1-1/2" FLAT HEAD SCREW
6. OUTSIDE HANDLE
7. OUTSIDE TRIM PLATE
8. D-CLIP
9. FLAT WASHER
10. T-BUSHING
11. SPINDLE
12. INSIDE HANDLE
13. INSIDE TRIM PLATE
14. #8-32 SCREWS
15. #8 FLAT HEAD SCREWS
16. STRIKE PLATE

*Style of handles and plates shown may vary from those packaged in your hardware kit.

STEP 1. LATCH INSTALLATION INSTRUCTIONS

IMPORTANT - DOOR JAMB (Z-BAR) HAS OPENINGS FOR BOLT EXTENSION. THE WOOD IN THESE OPENINGS MUST BE REMOVED TO A DEPTH OF 3/4" BEFORE OPERATING THE DEADBOLT WITH THE DOOR CLOSED. SEE STEP 3A.

A. From outside of door, determine if your door is a right hinged or a left hinged door. See Fig. 2.

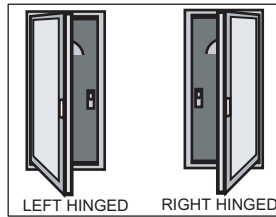

FIGURE 2

B. If the bolt orientation of the mortise plate and latch assembly matches your door go to **Step C**. If the bolt orientation is incorrect for your door, remove the #10-32 x 5/8 flat head screw and mortise plate. Rotate the latch bolt 1/2 turn (180 degrees) and reattach mortise plate to latch assembly. See Fig. 3.

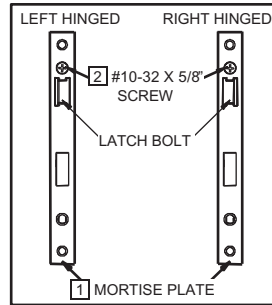

FIGURE 3

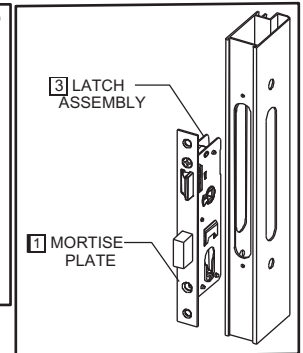

FIGURE 4

C. Insert latch assembly into end of door panel per Fig. 4. Do NOT fasten at this time, fastening will be completed in Step 2F.

STEP 2. OUTSIDE HANDLE AND ESCUTCHEON PLATE ASSEMBLY

A. On the inside of the door, insert key cylinder through the latch assembly, aligning the screw hole in the key cylinder with the hole in the mortise plate; insert the #10-32 X 1-1/2" flat head screw into the mortise plate and key cylinder. Prior to tightening the screw, turn the key cylinder to extend the deadbolt. Return the deadbolt to the fully retracted position after tightening the screw. See Fig. 5.

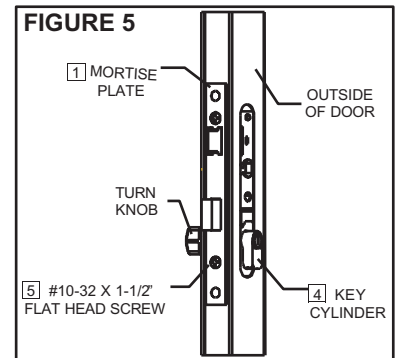

FIGURE 5

B. Insert outside handle through the T-bushing and outside trim plate. See Fig. 6.

C. On the back of the outside trim plate, place the flat nylon washer over the handle and slide the D-clip over the flat nylon washer, making sure that the D-clip is orientated vertically. Insert the square spindle all the way into the handle. Using the Hex wrench provided, tighten the set screw on the underside of the handle to hold the spindle in place. See Fig. 6.

D. From the outside of the door, insert the outside handle/trim plate/spindle assembly through the square hole in the latch assembly, making sure that the lever handle is facing in the correct direction.

E. On the inside of the door, position the inside handle, with T-bushing, through the inside trim plate and over the square spindle; making sure that the inside lever is facing in the correct direction. Align the trim plates and attach (from the inside of the door) using the two #8-32 attaching screws. Hold the handles snugly together and tighten the set screw on the interior handle using the hex key wrench supplied.

CAUTION: Do not over-tighten as plates may bend.

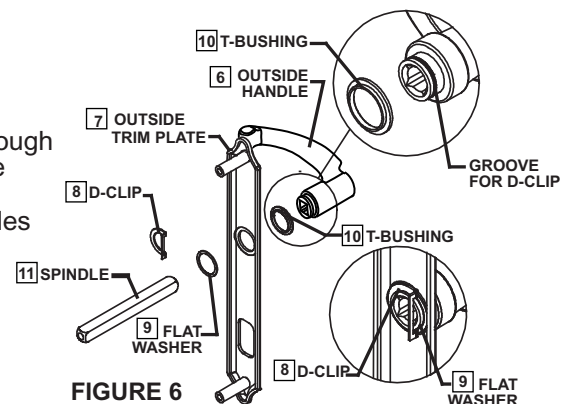

FIGURE 6

H. Centerpunch and drill 1/8" pilot holes and install the (2) #8 flat head screws in the edge of the door securing latch assembly to the door.

****To maintain proper operation of your door hardware, periodically check your mounting and set screws for tightness****

STEP 3. STRIKE INSTALLATION INSTRUCTIONS (OPTIONAL)

A. Using a drill and chisel, clear the wood from the strike openings behind the "Z" bar 3/4" deep. **See Fig. 7.**

B. With the door open, extend the deadbolt fully. Carefully close door until deadbolt contacts the z-bar. With a pencil, mark the location of the top and bottom of the deadbolt onto the z-bar. **See Fig. 8.** Return the deadbolt to the fully retracted position.

C. Position the strike plate on the latch side z-bar. Align the strike vertically by centering the bottom hole in the strike plate with the marks previously made on the z-bar. **See Fig. 9.**

D. Position the strike horizontally by aligning the outside edges of the top and bottom slots in the strike plate with the outside edges of the top and bottom slots in the z-bar. Mark the hole locations in the center of the two adjustable slots. **(Do not mark or drill center screw hole.)**

E. Remove the strike and drill the marked holes with a 1/8" drill bit. Reposition the strike and insert #8 flat head screws into the mounting holes and tighten. Close the door and check for proper operation of latch and deadbolt. Adjust the strike if needed.

F. With the strike in final position, drill remaining hole with a 1/8" drill bit. Insert #8 flat head screw and tighten.

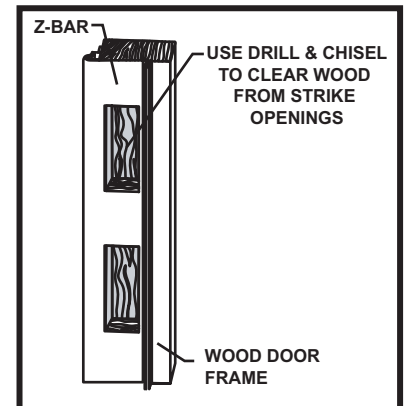

FIGURE 7

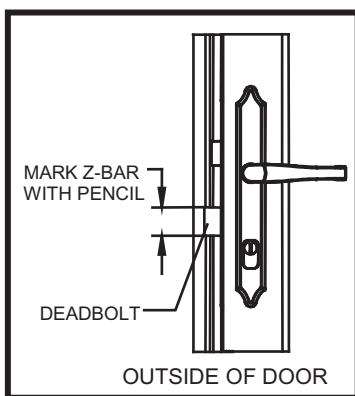

FIGURE 8

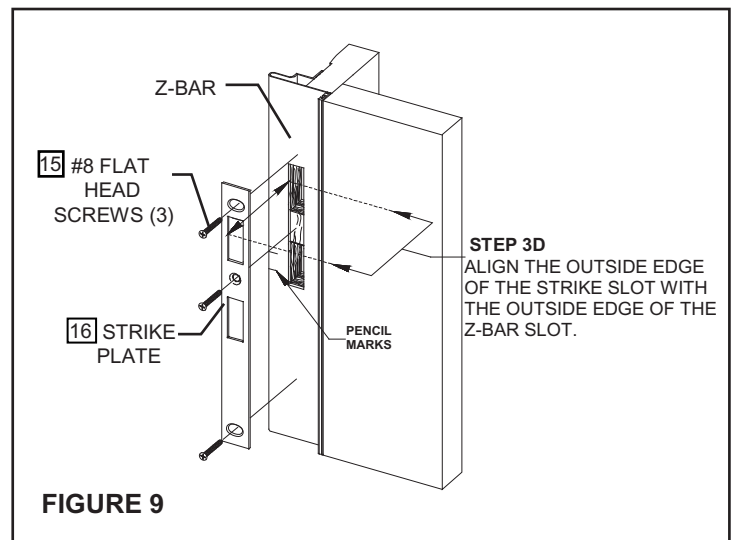

FIGURE 9